



Rigging & Sail Handling



Wykeham Martin Furling Gear

In continuous production for around 100 years, this traditional furling gear has been successfully fitted to thousands of boats worldwide. Cast in bronze from the original patterns, the parts are carefully machined, polished and assembled by English craftsmen to produce a beautiful and efficient furling system. Fitted with stainless steel thrust races to ensure free running and easy sail furling. An information leaflet is available on request.

Dimensions in mm's

Top Swivel	Drum	Size	Approx. Sail Area		A	B	C	D	E
			sq. ft	sq. m					
9443/GM/01/TS	9443/GM/01/DR	1	50	5	72	10	eye	85	62
9443/GM/2B/TS	9443/GM/2B/DR	2B	100	10	100	18	11	128	85
9443/GM/3B/TS	9443/GM/3B/DR	3B	200	20	110	20	12	135	95
9443/GM/4B/TS	9443/GM/4B/DR	4B	350	35	150	28	16	165	150

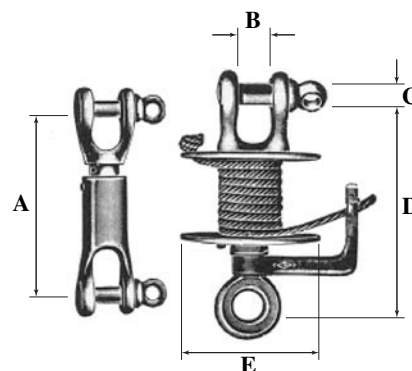

Highfields Pattern Running Backstay Lever

Gunmetal channel section, polished outside and pivoted with two side bolts leaving the channel clear for the wire to lie in. When the lever is down the wire is below the pivot point therefore the greater the stress, the more firmly the runner is locked. Quick release device also available.

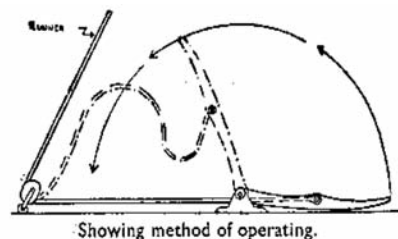

Lever	Size No	Wire	Lever Length		Base Size	
2655/GM/01	1	6mm	10"	250mm	3¼" x 1⅜"	95 x 35mm
2655/GM/02	2	8mm	16"	406mm	5" x 1¼"	125 x 46mm
2655/GM/03	3	10mm	23½"	597mm	7¼" x 2⅝"	196 x 67mm

Traditional Ash Mast Hoops

Traditional mast hoops made from ash and copper riveted, finished with 2 coats of linseed oil. Also available with stainless steel bolts so that the hoop can be fitted to a stepped mast. Other sizes also available.

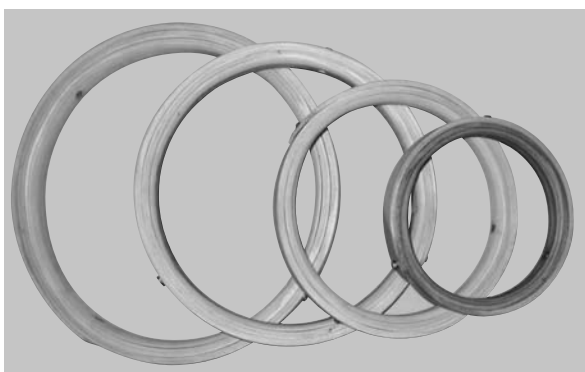

Inside Diameter	Copper Riveted	Bolted
6"	0960/AH/150	0961/AH/150
7"	0960/AH/175	0961/AH/175
8"	0960/AH/200	0961/AH/200
9"	0960/AH/225	0961/AH/225
10"	0960/AH/250	0961/AH/250
12"	0960/AH/300	0961/AH/300